

www.mysafe.world

mysafe
Manage & Control.
Anytime. Anywhere.



Technical & Installation instructions



 Download on the
App store



 Download on the
Google play

CERTIFICATE



The **European Certification Body GmbH** accredited according to ISO/IEC 17065 awards to

MySafe Locking Systems s.r.o.
Varsavska 715/36, 1200 Praha 2 / CZ

the right to carry the **ECB•S** certification mark for

High security locks of class B according to EN 1300:2018 and ECB•S C10
(Series: MySafe high security safe lock – Lock types: T4801 and T4801M – electronic lock)
(see Annex)

Certificate Number

2401/HSL24-01

30 April 2024

valid from

29 April 2028

valid until

30 April 2024

Frankfurt am Main

Dr. Markus Heering

Certification Body



ECB•S

European Certification Body GmbH
Lyoner Straße 18 • 60528 Frankfurt am Main • Germany
www.ecb-s.com

About Mysafe COMM UNIT

The MySafe COMM UNIT is connected between the safe lock and the entry unit and can eavesdrop on the communication between the two. It sends status information to a central server from where the information can be received using the MySafe App.



Depending on the settings, the device can block the opening of the safe and switch its outputs based on selectable lock events. The COMM UNIT is installed inside the safe and communicates with the outside world via Ethernet using an encrypted MQTTS connection. A single cable is sufficient for connection, as the device is powered via an Ethernet cable according to the PoE standard.

- **Default IP adress COMM UNIT: 192.168.1.254**

COMM UNIT > Connections

Using PoE injector ?

By the use of a PoE injector, be careful about the connection.

- **LAN connector to network (Switch/Router)**
- **PoE connector to COMM UNIT**

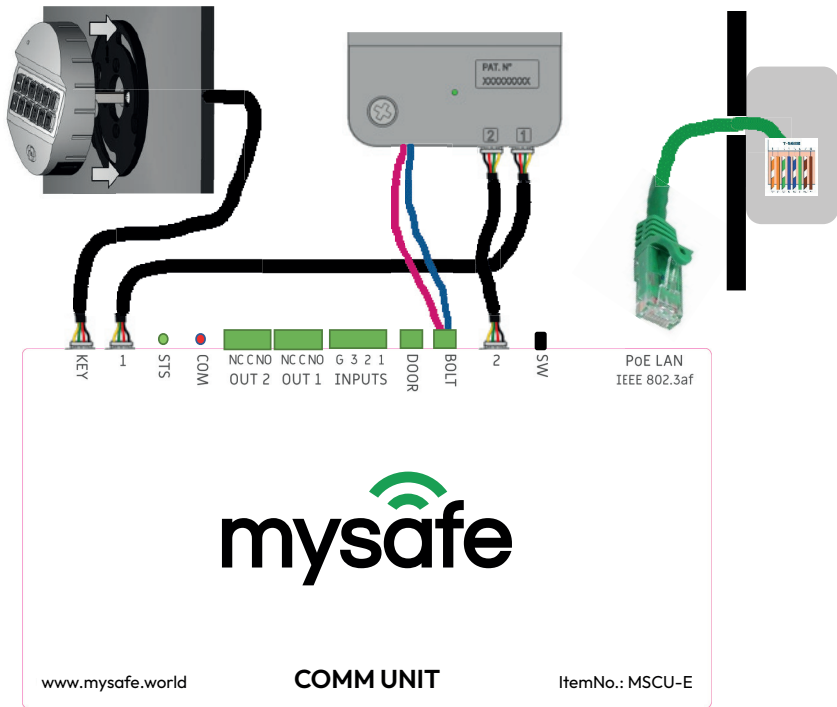

Meaning of the two small LED:

- **STS:** The Status LED lights up after the device has been properly initialized.
- **COM:** The Communication LED stays lit up after establishing secure connection to the web server.
- It blinks if switch SW was pressed and configuration page is available (see section configuration, page 12).

COMM UNIT > Connections

Connectors 1 & 2

- Use provided connection cables (90 cm) with white pico-Spox connectors for connection to the safe lock (Lock connector 1 to COMM UNIT connector 1, 2 to 2).

Bolt

- Connect the two wires from the lock into the green push terminal (polarity irrelevant).

KEY connector

- Use connection cable (90 cm) with white Pico-Spox connector from the entry unit.

DOOR connector

- Used to connect a door sensor (polarity irrelevant). The logic (NO or NC) of the sensor can be reversed by the supplied jumper (section K13).
 - **Default COMM UNIT setting: door sensor normally opened - NO**
 - By using door sensor „**normally closed (NC)**“ the jumper bridge is needed.

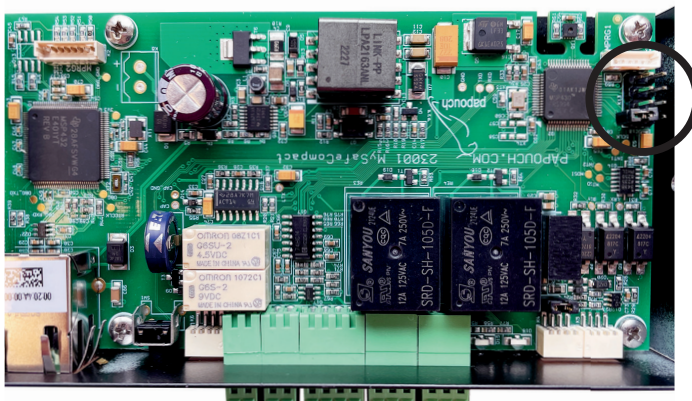

Door sensor: NO



Door sensor: NC



COMM UNIT > Connections

Inputs connector

- Three universal switch inputs. The switch connects between contact G (ground, common) and contact 1, 2, or 3 (see also section setting, page 8).

OUT1 and OUT2 connectors

- Universal relay outputs with changeover contact. The autonomous functions of the outputs are set via the web interface (see section settings, page 8).

Ethernet and power

- Connect the COMM UNIT to the LAN-switch with a regular patch cable for computer networks.
- For a switch that cannot power the device via PoE according to the IEEE 802.3af standard, use a proper PoE-Injector (sold separately).
- The connection of the LAN cable between the RJ45 connector on the outside of the safe and the connector inside is governed by TIA-568B (see ANSI/TIA 568 Wiki).

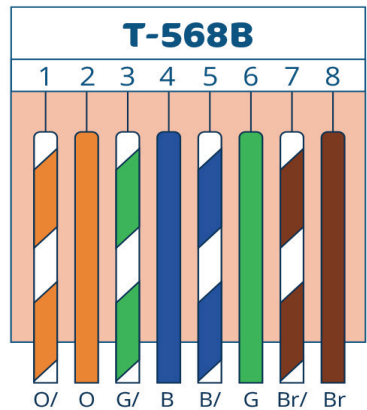

Two lights in the Ethernet connector

- **Yellow** – LINK:
Lights up when the device is connected to a switch or PC by cable.
- **Green** – ACT:
Indicates communication with the network switch.

COMM UNIT > Dimensions and installation

Install lock and entry unit according to their installation instructions to maintain the lock certifications (EN1300 Class B and UL Type 1).

- The only difference is that lock and entry unit are connected via the COMM UNIT



The lock will be powered through the connection to the COMM UNIT.

- Use the battery compartment in the entry unit only in case of power loss or to check the unit during installation.
- In case it is not wished that the COMM UNIT powers the lock it is possible to suppress this by removing jumper J2 inside the device. It connects 9V power for the entry unit and lock. The jumper is factory-connected.

COMM UNIT > Dimensions and installation

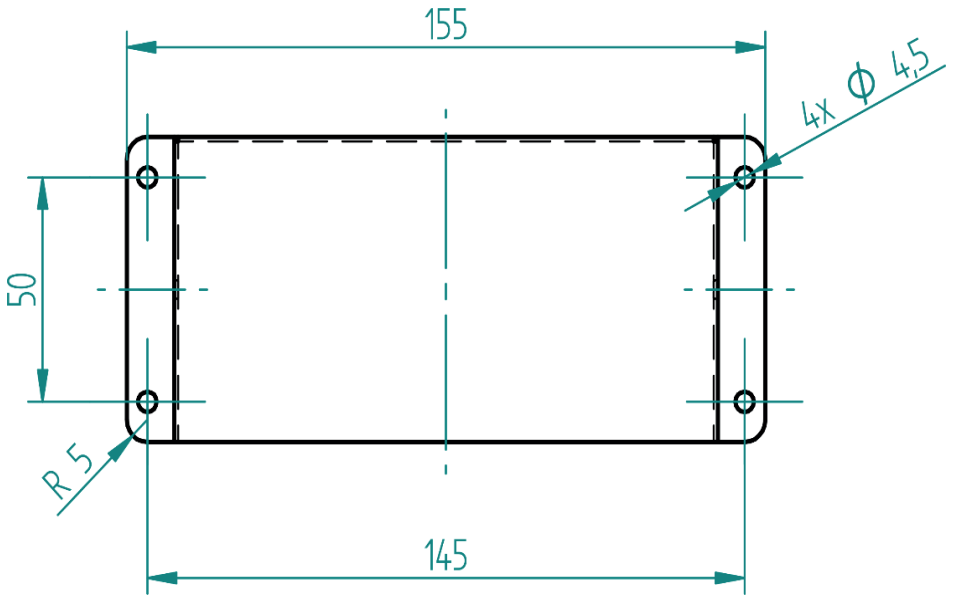

Install the COMM UNIT with 4 screws 3,5x16 mm inside the safe.

- Install preferably with the connector side up (this puts the temperature sensor in the bottom and prevents the green connectors from falling out, should they ever come loose).
- Drill a hole with a diameter of 6 mm to the safe where you want to place the Ethernet connector.
- Such access to the safe is in accordance with the EN1143-1 standard

COMM UNIT > Settings/Basic configuration

While the lock is open, it is possible to access the configuration page of the COMM UNIT via a web browser. The PC or Laptop needs to be **the same network as the safe**.

In order to access the page, type the **current IP-Address (not identical with the default IP address by using DHCP router or a specific static IP address)** of the device in the browsers address line.

TIP: The IP-Address of the device (if already registered in the MySafe App) is shown in the status page of the MySafe App.



The factory default password is **123456**

Password

Login

After login, settings for the network, password and time synchronization are available.

COMM UNIT > Settings/Basic configuration



Network

Security

Other

Comm Unit Settings

[Save](#) [Default](#) [Refresh](#) [Logout](#)

Type:	MySafe Comm Unit ETH	Unit date and time:	31.3.2023 07:27:23 UTC
Firmware version:	1.4/8	Technical support:	mysafe.world
Serial number:	1571/0002		
MAC:	00-11-22-33-AA-FF		
Core version:	MySafeCompact; v1571.01.01;		
Browser:	Firefox 114		

Unit name:

Language:

Network

DHCP

Device's IP address:

Netmask:

Gateway IP address:

DNS server's IP address:

WEB port:

Security

Current password:

New password:

Confirm password:

Other settings

Synchronize device's time with this PC's time:

[Update Firmware](#)

Temperature monitoring

Upper limit:

Lower limit:

Other settings

Synchronize device's time with this PC's time:

[Update Firmware](#)

Any changes to the settings become only valid after saving (and rebooting unit).

- **Attention:** Changing the IP address may make the unit inaccessible (also for the MySafe App) until a reset is performed by a service technician.



Network

Security

MQTT

Outputs

Temperature

Other

Comm Unit Settings

Type: MySafe Comm Unit ETH
 Firmware version: 1.4/8
 Serial number: 1571/0002
 MAC: 00-11-22-33-AA-FF
 Core version: MySafeCompact; v1571.01.01;
 Browser: Firefox 114
 Unit date and time: 31.3.2023 06:58:48 UTC
 Technical support: mysafe.world

Unit name:
 Language:

Network

DHCP:
 Device's IP address:
 Netmask:
 Gateway IP address:
 DNS server's IP address:
 WEB port:

Security

Current password:
 New password:
 Confirm password:

MQTT

Broker:
 Certificate:
 QoS:
 Publish to topic:
 Subscribe to topic:
 Login name:
 Login password:
 Confirm password:

Outputs - autonomous function

OUT 1

Event to switch on:
 Switch on duration [ms]:
 Event to switch off:
 Switch off duration [ms]:

OUT 2

Event to switch on:
 Switch on duration [ms]:
 Event to switch off:
 Switch off duration [ms]:

Temperature monitoring

Upper limit:
 Lower limit:

Other settings

Synchronize device's time with this PC's time:

COMM UNIT > Settings/Full configuration

Trained safe technicians can access the **full configuration page** as follows:

1. Open the lock
2. Press and hold the SW button on the device
3. Between about 3 and 5 seconds, the COM light flashes
4. While the indicator light is flashing, release the SW button
5. Complete settings are accessible after login

TIP: The IP-Address of the device is shown in the status page of the MySafe App.

Configuring the outputs (e.g. alarm)

The COMM UNIT provides two output contacts. Each can be connected either to close or open an independent electric circuit. Examples could be sending an alarm or activating a separate device.

Innovative is the flexibility in how these outputs can be configured.



TIP: In the configuration page “switch on” means that the relay is activated thru switching the NC contact to open and the NO contact to close.

Event to switch on:

- The relay is triggered by any event of the lock that can be selected from the drop-down list.

Switch on duration [ms]:

- The time in milliseconds how long the relay is to stay on (1000 ms = 1 second).
- 0 = indefinitely ON
- Event to switch off:
The relay goes back to normal if the selected event happens (this is optional).

Switch off duration [ms]:

- The time in milliseconds how long the relay is to stay off (1000 ms = 1 second).
- 0 = indefinitely OFF

COMM UNIT > Settings/Full configuration

Temperature monitoring

The COMM UNIT measures temperature and humidity continuously and sends this information to the web server every two minutes. It is shown in the safe status section of the MySafe App.

Additionally, events are triggered if the temperature rises above or drops below of values that are defined in the configuration page. The events are shown in the audit and can raise a message in the app.

In PRO version is available auto block of safe when the upper limit T1 or T2 is reached. This functionality can protect the safe's operator from possible injury, e.g. in the case of a fire in the safe.

Upper limit: (Default set to 70 degr Celsius)

Lower limit: (Default set to 35 degr Celsius)

COMM UNIT > Reset (Factory settings)

1. Disconnect the PoE LAN cable from the COMM UNIT
2. Press and hold the SW button
3. While the SW button is pressed, connect the PoE LAN cable to the COMM UNIT
4. Hold the SW button pressed for another 1-2 seconds
5. Release the SW button
6. Your COMM UNIT is reset now to default IP address: **192.168.1.254**

For security reasons

The complete configuration is only available to a trained service technician as it requires direct contact with the COMM UNIT itself. (The configuration page is accessed via a http connection and therefore could be intercepted from a foreign device that is on the same network as the Comm Unit.)

SAFE LOCK > Setup for mysafe compatibility



Pulse PRO

High Security Lock – VdS Class 2
– EN1300 Class B

How the lock is set

Pulse PRO setup for MySafe:

- **Basic configuration**
 - 1 Manager
 - 1 Master
 - 1 ERC (Emergency Rescue Code)
 - 49 Users
- **Function „Silent alarm“ is activated:**
- **Remote override is activated**

SAFE LOCK > Installation

Keypad dimensions

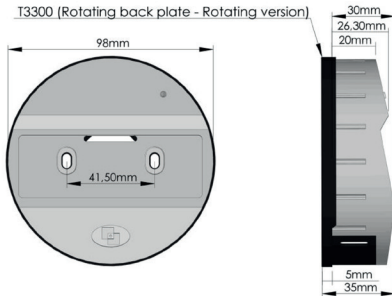

2 pcs. screws M4 x 16 mm for keypad unit
2 pcs. screws M4 x 10 mm for mounting plate



If you don't use the mounting plate, screws M4x10 for keypad is OK

T4801 - SwingBolt dimensions

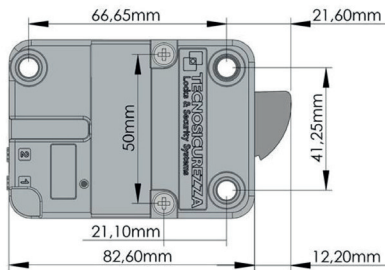

3 pcs. screws M6 x 25 mm for swingbolt lock

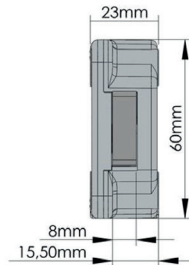

T4801/M - MotorLock dimensions

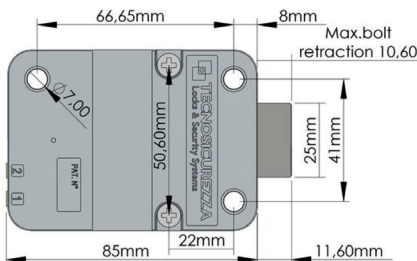

3 pcs. screws M6 x 34 mm for motorlock lock

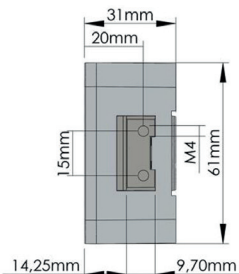

Important

If locks are not properly protected by systems belonging to the safe (manganese plates, glass plate, relocking, etc.) only MotorLock locks can be mounted behind the passage hole for the connection cable.



Add the safe to the APP

The following steps are required to make the status of the safe visible in the MySafe App.



 Download on the **App store**



 Download on the **Google play**

MySafe app

Add new safe

- Press button Add Safe in the app
- Then select “I have QR code”
- Scan QR code on the Comm unit
- Press Next
- Select time zone for the safe
- Finish registration

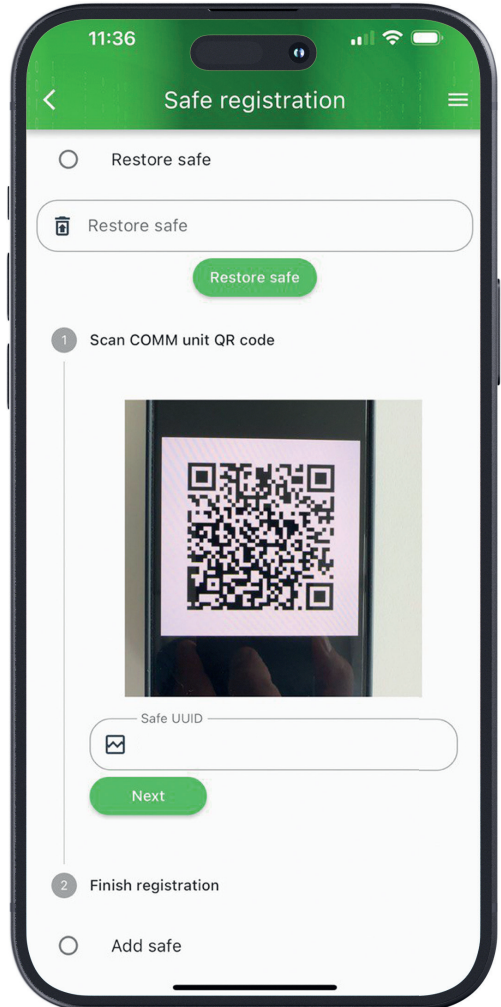

Now your safe is visible in the app and you can manage whatever you want.

MySafe app

Add a safe after reset Comm Unit to default setting

**Your smartphone need to
be the same network as the
safe.**

- Connect your phone to Access Point/Router with IP address range set from 192.168.1.20 to .250
- Access Point/Router should support DHCP
- Press button Add Safe in the application
- While lock is opened, press and hold the SW button on Comm Unit until the red light is flashing (3-5 sec.) Then release the SW button
- Select Add safe
- Enter your password for comm unit
- Press button Next

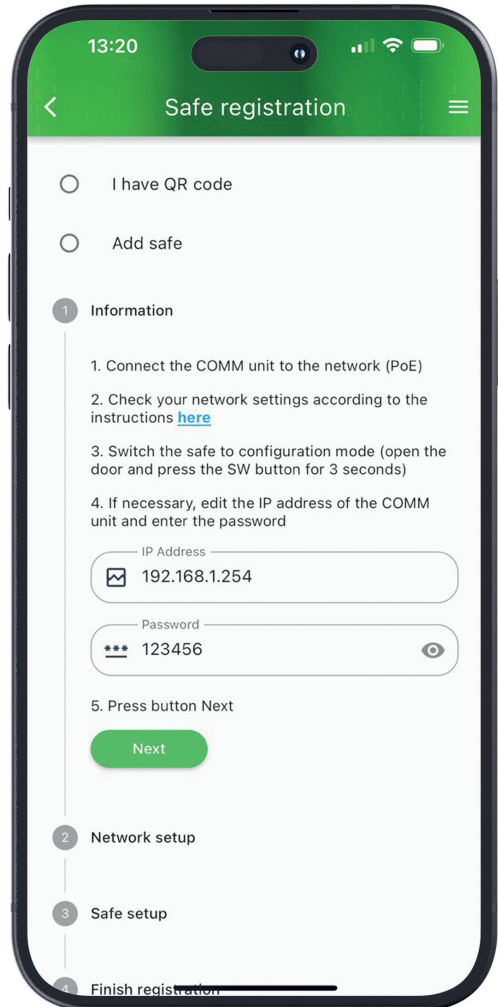

MySafe app

Add a safe after reset Comm Unit to default setting

- COMM UNIT at factory default configuration is accessible at IP 192.168.1.254
- Should you wish to pair the COMM UNIT with custom settings, you require the IP address of the COMM UNIT (can be scanned using some 3rd party IP scanner tool)
- Set required network settings (safe IP address or DHCP)
- Press button Next
- Safe HW-Id should appear (it matches the MAC address of COMM UNIT)
- Press Save (this step will save the safe configuration to the COMM UNIT)
- Name your safe and press finish (this step will save the safe to the MySafe database)
- Now you have your safe added into your app (you are automatically set as admin for the restored safe)

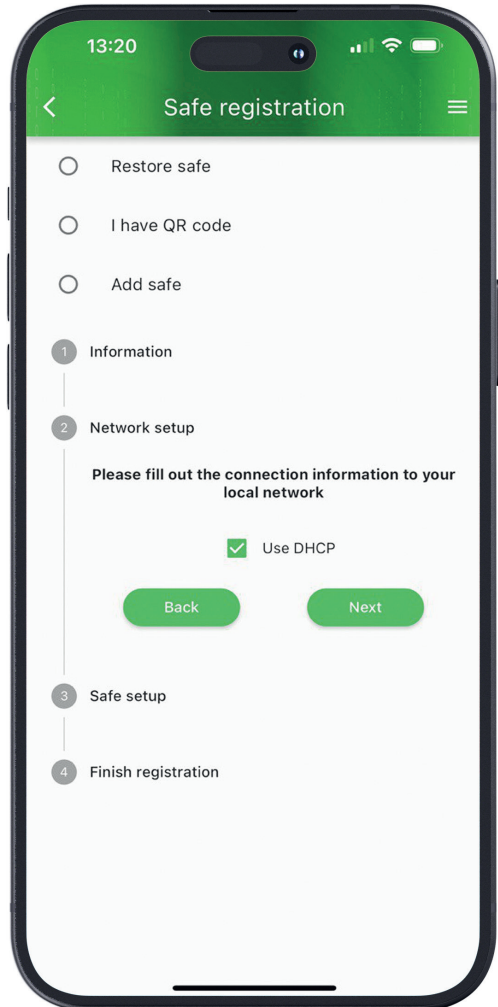

MySafe app

Potential problems:

- Should the safe HW-Id not appear – check network setup (IP address of the safe and your smartphone at the step 1)
- Error during finish step:
 - Reason 1: Another safe with same HW-Id is already registered
 - Reason 2: Network problem (your smartphone or safe has some problem to access the internet)

Recommended:

If you add a safe to the MySafe App, we always recommend activating DHCP (see screenshot on page 19). In this case be sure, that Access Point/Router support DHCP.



www.mysafe.world/tips-and-tricks



Technical parameters

Technical parameters

Relay outputs

Relay switching contact type

Maximum switching voltage	AC: 60 V, DC 85 V
Maximum switching current	5 A
Protective varistor	UAC = 60 V; EMAX = 5 J; C = 0.64 nF

Lock control output (BOLT)

Load capacity	max. 9 V / 100 mA
---------------	-------------------

Relay inputs

Contact connection type

Current through closed contact	typ. 2.3 mA
--------------------------------	-------------

Temperature and humidity measurement

Measured humidity range	0% to 100% RH (non-condensing)
Recommended measurement range	20 - 80%
Resolution	1% RH

Technical parameters

For humidity measurement accuracy

see fig. 6

Measuring element

polymer sensor

Mechanical design of the sensor

under the plastic mesh from above on the device

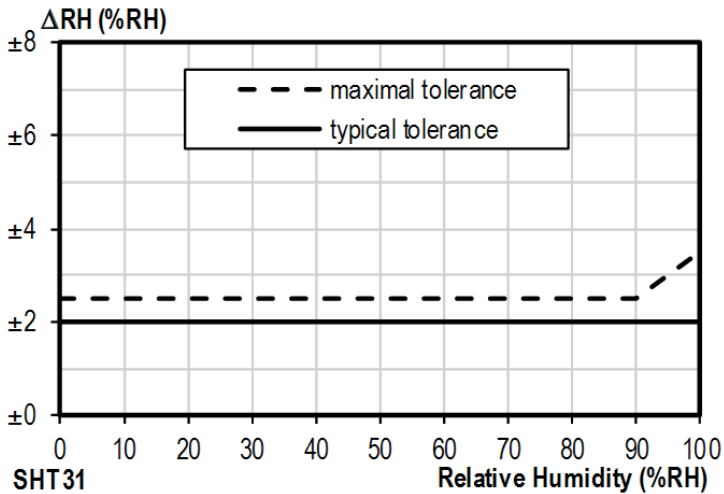

fig. 6

Range of measured temperatures

-40.0 °C to +125 °C

Resolution

0.1 °C

Measuring element

semiconductor sensor

Technical parameters

Ethernet

Ethernet	TBase 10/100 Ethernet
PoE power supply	according to IEEE 802.3af
Communication method with server	MQTTS (TLS 1.2)
Maximum length of SSL certificate	4 KB
communication format	JSON

Default Ethernet settings

IP address	192.168.1.254
Netmask	255.255.255.0 (8 bits; C mask)
IP address of the gateway (Gateway)	0.0.0.0

Types of connectors

Ethernet	RJ45
1, 2 and KEY	Molex 87438-0443
BOLT, DOOR	15EDGRC-2.5-02P-14-00A
OUT1, OUT2	15EDGRC-2.5-03P-14-00A
INPUTS	15EDGRC-2.5-04P-14-00A

Other

Device tamper detection	yes, shock and tilt detecting accelerometer
Consumption	typ. 1.2 W (at rest, without lock attached)
Degree of protection	IP 20
Working temperature range	-20 to +60 °C
Maximum working humidity	90% RH, non-condensing
Dimensions	155 x 68 x 28 mm

Technical parameters

Troubleshoot/Reset

If IP address was changed to a static IP (DHCP unchecked) and the configuration page is not accessible, the following procedure can restore activation of DHCP:

- 1) Keep the SW button on the device pressed for 15 seconds until the red COM LED starts flashing for the second time.
- 2) Release the button. The device will receive (and store) a new IP-Address from the DHCP server. Other settings remain unchanged.

To reset the device to default settings use the following procedure:

- 1) Unplug the power connection (PoE).
- 2) Keep the SW button pressed while you re-connect power.
- 3) Keep the SW button pressed until the red COM LED starts flashing (3-5 sec.)
- 4) The flashing indicates the unit is set to default.

COMLED status

Power	SW button	COM LED
ON	not pressed	Continuously ON when secure connection to WebServer is established.
Connect	pressed	Flash to indicate reset.
ON	pressed and hold 3 seconds	Flash for 5 seconds. If button released during this time (and lock open) full configuration page is available.
ON	pressed and hold 15 seconds	Flash for 5 seconds. If button released during this time DHCP is activated.
ON	pressed and hold 60 seconds	Flash for 5 seconds. If button released during this time device allows firmware update (procedure for firmware update is not part of this instruction).

Technical & installation tips

Software Button functions

	Lock open	SW Press + Hold Flash 1	SW Press + Hold Flash 2
Restart safe	✓	✓	
COM Unit Settings	✓	✓	
DHCP	✓		✓

Reset COM Unit

	SW Button Press + Hold	LAN (PoE) Plug In
Reset	✓	✓

Outputs

We recommend activating the outputs in the Comm unit settings. Only then is it possible to manage the outputs with the app.

mysafe override

We recommend to repeat the activation and deactivation of the mysafe override function at least 2 times at the beginning of using the lock.

Door sensor

Install the sensor (with wires) on the door, the magnet on the frame of the safe (inside). Make sure that the gap between the sensor and the magnet is not more than 10 mm

Cable transition

Screw the transition so that it is not deformed when the door is closed. Tighten the screws so that they do not loosen during subsequent handling.

Technical & installation tips

Comm Unit

Screw the Comm Unit with the supplied screws inside the doors near the lock. If screws are not possible, you can stick the Comm Unit with professional velcro tape. It's also possible to screw the Comm Unit on other suitable place inside the safe, e.g. roof, doors etc..

LAN connector RJ45

For the LAN connector, choose a place on the safe so that it does not obstruct the movement of people around the safe.

WEEE-Note

The WEEE (Waste Electrical and Electronic Equipment) Directive, which was incorporated into European legislation on February 13, 2003, has led to a far-reaching rethinking of the disposal of electrical and electronic equipment. The WEEE logo on the product or its packaging means that this product must not be placed in your household waste. You are responsible for taking any harmful waste electrical and electronic equipment to designated collection points. You can help protect the environment by isolated collection and proper recycling of your electrical and electronic waste. Proper recycling of electrical and electronic equipment promotes overall health and protects the environment. For more information on disposal, reuse and collection of electrical and electronic waste, contact your local waste disposal service, recycling centers, and the seller and manufacturer of the equipment.

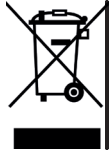

Usefull link:

Full PulsePro User manual download: mysafe.world/download

Your MySafe package contents

Quantity

• MySafe COMM UNIT – Ethernet	1	<input type="checkbox"/>
• Tecnosicurezza Pulse PRO keypad	1	<input type="checkbox"/>
• Pulse PRO keypad mounting plate	1	<input type="checkbox"/>
• Tecnosicurezza Pulse PRO – Swingbolt lock	1	<input type="checkbox"/>
– Motor lock	1	<input type="checkbox"/>
• Bag of screws – Lock & Keypad	1	
• 3 pcs. screws M6 x 34 mm for MotorLock lock		<input type="checkbox"/>
• 3 pcs. screws M6 x 25 mm for SwingBolt lock		<input type="checkbox"/>
• 2 pcs. screws M4 x 16 mm for Keypad		<input type="checkbox"/>
• 2 pcs. screws M4 x 10 mm for mounting plate		<input type="checkbox"/>
• Tecnosicurezza cable to connect COMM UNIT with lock	2	<input type="checkbox"/>
• LAN cable 2,5 m	1	<input type="checkbox"/>
• LAN connector RJ45	1	<input type="checkbox"/>
• Door sensor	1	<input type="checkbox"/>
• Cable transition (incl. 2 end caps)	1	<input type="checkbox"/>
• Bag of screws (3,5 x 16 mm)	1	
• 4 pcs. screws for COMM UNIT		<input type="checkbox"/>
• 4 pcs. screws for cable transition end caps		<input type="checkbox"/>
• 2 pcs. screws for LAN connector RJ45		<input type="checkbox"/>

Optional:

• Tecnosicurezza Pulse PRO Keypad with Dallas terminal	1	<input type="checkbox"/>
• LAN connector holder (for single-wall safes)	1	<input type="checkbox"/>
• MySafe PoE injector according to the IEEE 802.3af standard	1	<input type="checkbox"/>
• Cable transition for multiple cable (incl. 2 end caps)	1	<input type="checkbox"/>
• Mounting plate	1	<input type="checkbox"/>